

Area  
 Gross: 87,163 Sq. Ft. = 2.001 Ac.  
 R/W: 8,245 Sq. Ft. = 0.189 Ac.  
 Net: 78,918 Sq. Ft. = 1.812 Ac.

Valerie G. Whipple, Trustee  
 O.R. 3294, P. 0602 and O.R. 3294, P. 0614  
 Parcel # L45-412-3300000080000

# A Parcel Split for Stanley Patten being part of the northwest 1/4 of Section 33, Town-4-North, Range-12-East, Montgomery Township, Wood County, Ohio

References:  
 Surveys:  
 E. VanHorn, 5-13-96, #266 Mont.  
 C. Perry, 5-22-02, #349 Mont.

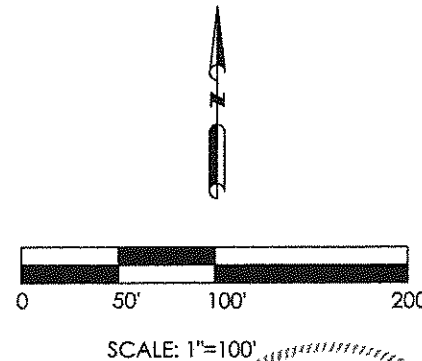

I hereby state that this drawing represents a survey made by me and is correct to the best of my knowledge, information and belief.

*Dennis L. Whiting*  
 Dennis L. Whiting, P.S.  
 Ohio Reg. Surveyor No. S-8380

## Notes:

- Bearings are based on State Plane Grid, Ohio North, NAD83 (2011).
- Whiting Surveys provides information regarding easements furnished to them by the title company or that they have knowledge of. Therefore, easements shown or not shown are not guaranteed to be complete.
- All iron pins set are 5/8"x30" with cap stamped D.WHITING 8380

LEGEND	
●	Iron Pin Set
○	Iron Pin Found
⊖	Iron Pipe Found
•	Mag Nail Set

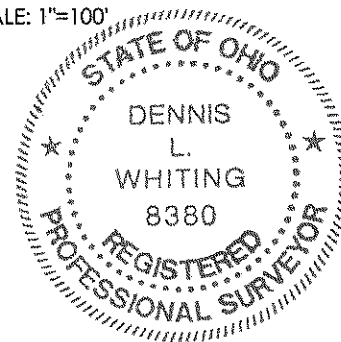

W	<b>WHITING SURVEY</b>	
	Surveyors 493, Shoop Avenue Wauseon, Ohio 43567 Phone: 419-335-7212 Cell 567-454-0409	
DRN BY:	dlw	CHKD BY: dlw
DATE:	4-8-16	PROJ. NO.: 16-159-001
Parcel Split on Bays Road		

